

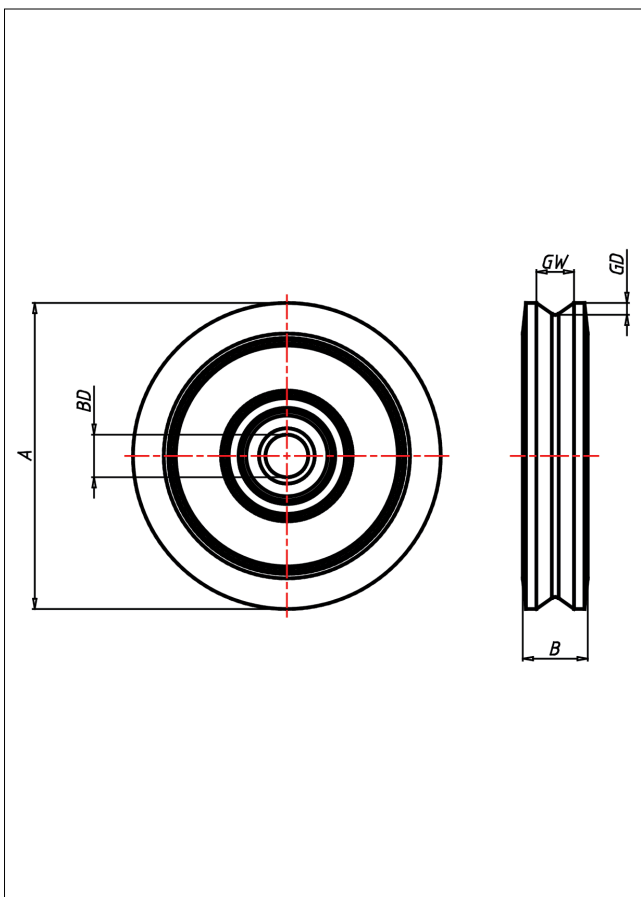

Seilrollen aus Stahl

Seilrolle



Seilrollen Stahl Seilrollen aus Stahl



Seilrolle aus Stahl
abgedichtetes Kugellager

- sehr hohe Tragkraft
- Seilnille voll bearbeitet

Technische Details

ORDERNO (Artikel-nummer)	181/300
WDAB (Rad-Ø A x Breite B / mm)	300x60
LC (Tragkraft / kg)	6400
GD (Nutm-tiefe / mm)	12.5
GW (Nutm-breite / mm)	35
HW (Nabellänge / mm)	52
FL (Einbaulänge / mm)	52
WB (Radlager)	Ball bearing
BD (Bohrungsdurchmesser / mm)	45