

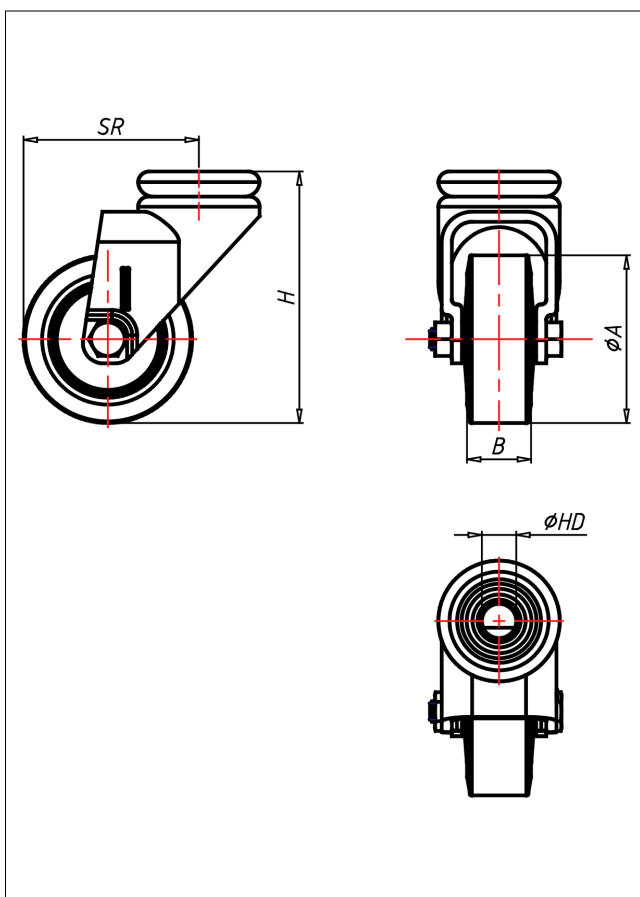

310X RÜ-G

Lenkrolle



310XR-G



| LENKROLLE | LENKROLLE MIT TOTALFESTSTELLER | | | | | | | | | | | | | | | | | | | | | |
|---|---|---|----------------|---|---|----|---------------|---|---|---|----------|---|---|---|---------------|---|---|---|---------------------|---|---|---|
| | | | | | | | | | | | | | | | | | | | | | | |
| <ul style="list-style-type: none"> • spurfrei • geräuscharmer Lauf • großer Fahrkomfort • beständig gegen verdünnte Säuren Thermoplastisches Elastomer Felge Polyamid 6 → Seite 268 | zweifaches Kugellager - vernietet, Radachse verschraubt - gesichert, alle Teile aus Edelstahl rostfrei → Seite | AUSWAHLHILFE: <table border="1"> <tr> <td>leicht lenkend</td> <td>+</td> <td>-</td> <td>++</td> </tr> <tr> <td>verschleißarm</td> <td>x</td> <td>o</td> <td>o</td> </tr> <tr> <td>stoßfest</td> <td>x</td> <td>o</td> <td>o</td> </tr> <tr> <td>bodenschonend</td> <td>o</td> <td>o</td> <td>x</td> </tr> <tr> <td>witterungsbeständig</td> <td>o</td> <td>o</td> <td>x</td> </tr> </table> | leicht lenkend | + | - | ++ | verschleißarm | x | o | o | stoßfest | x | o | o | bodenschonend | o | o | x | witterungsbeständig | o | o | x |
| leicht lenkend | + | - | ++ | | | | | | | | | | | | | | | | | | | |
| verschleißarm | x | o | o | | | | | | | | | | | | | | | | | | | |
| stoßfest | x | o | o | | | | | | | | | | | | | | | | | | | |
| bodenschonend | o | o | x | | | | | | | | | | | | | | | | | | | |
| witterungsbeständig | o | o | x | | | | | | | | | | | | | | | | | | | |

Technische Details

| | |
|---------------------------------------|---------------------|
| ORDERNO (Artikel-nummer) | 310X RÜ 100 G |
| WDAB (Rad-Ø A x Breite B / mm) | 100x25 |
| LC (Tragkraft / kg) | 50 |
| H (Bauhöhe H / mm) | 125 |
| HD (Loch-Ø / mm) | 10.2 |
| SR (Schwenkradius / mm) | 85 |
| WB (Radlager) | Polyamid-Gleitlager |