

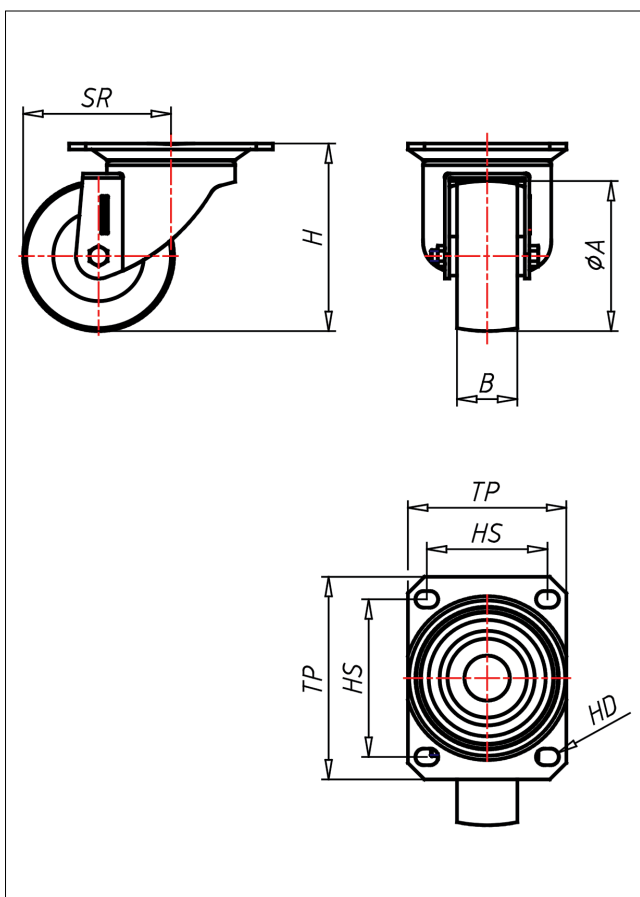

69A/69SP/69S/PS125- BA Lenkrolle



69-BA



LENKROLLE	LENKROLLE MIT TOTALFESTSTELLER	90° RICHTUNGSFESTSTELLER																				
 <ul style="list-style-type: none"> • minimaler Rollwiderstand • geräuscharmer Lauf • sehr niedrige Abriebswerte • lange Lebensdauer • sehr beständig gegen viele aggressive Medien <p>Vulkollan® Reifen ballig gegossen Felge - Vollkern aus Aluminium</p> 	 <p>sehr großes Schwenklager, Staubschutzring, starker Zentralbolzen verschraubt - gesichert</p>	 <p>AUSWAHLHILFE:</p> <table border="1"> <tr> <td>leicht lenkend</td> <td>+</td> <td>+</td> <td>+</td> </tr> <tr> <td>verschleißarm</td> <td>+</td> <td>+</td> <td>+</td> </tr> <tr> <td>stoßfest</td> <td>+</td> <td>+</td> <td>+</td> </tr> <tr> <td>bodenschonend</td> <td>+</td> <td>+</td> <td>+</td> </tr> <tr> <td>witterungsbeständig</td> <td>+</td> <td>+</td> <td>+</td> </tr> </table>	leicht lenkend	+	+	+	verschleißarm	+	+	+	stoßfest	+	+	+	bodenschonend	+	+	+	witterungsbeständig	+	+	+
leicht lenkend	+	+	+																			
verschleißarm	+	+	+																			
stoßfest	+	+	+																			
bodenschonend	+	+	+																			
witterungsbeständig	+	+	+																			

Technische Details

ORDERNO (Artikel-nummer)	69A/50-42/1
WDAB (Rad-Ø A x Breite B / mm)	50x42
LC (Tragkraft / kg)	100
H (Bauhöhe H / mm)	85
TP (Plattengröße / mm)	95x70
HS (Lochabstand / mm)	75x50
HD (Loch-Ø / mm)	7
SR (Schwenkradius / mm)	63
WB (Radlager)	Kugellager