

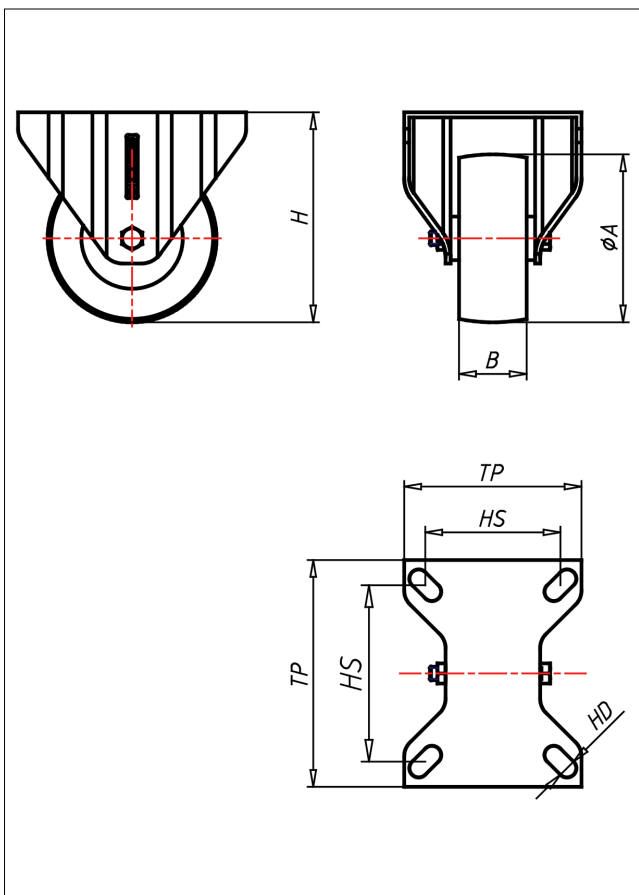

# 69B-BA

## Bockrolle

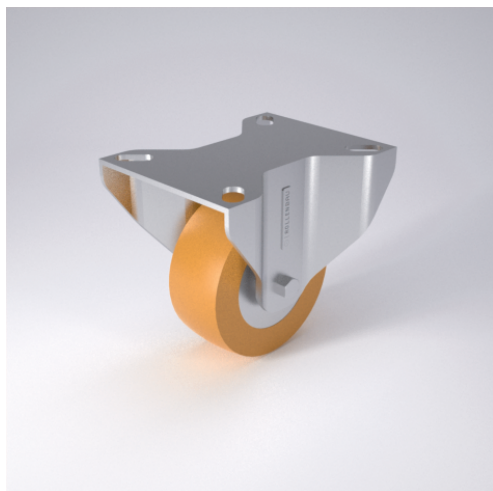

### 69-BA



LENKRÖLLE	LENKRÖLLE MIT TOTALFESTSTELLER	90° RICHTUNGSFESTSTELLER																				
<ul style="list-style-type: none"> <li>• minimaler Rollwiderstand</li> <li>• geräuscharmer Lauf</li> <li>• sehr niedrige Abriebswerte</li> <li>• lange Lebensdauer</li> <li>• sehr beständig gegen viele aggressive Medien</li> </ul>	<ul style="list-style-type: none"> <li>• sehr großes Schwenklager, Staubschutzring, starker Zentralbolzen</li> <li>• verschraubt - gesichert</li> </ul>	<p>AUSWAHLHILFE:</p> <table border="1"> <tr> <td>leicht lenkend</td> <td>+</td> <td>+</td> <td>+</td> </tr> <tr> <td>verschleißarm</td> <td>+</td> <td>+</td> <td>+</td> </tr> <tr> <td>stoßfest</td> <td>+</td> <td>+</td> <td>+</td> </tr> <tr> <td>bodenschonend</td> <td>+</td> <td>+</td> <td>+</td> </tr> <tr> <td>witterungsbeständig</td> <td>+</td> <td>+</td> <td>+</td> </tr> </table>	leicht lenkend	+	+	+	verschleißarm	+	+	+	stoßfest	+	+	+	bodenschonend	+	+	+	witterungsbeständig	+	+	+
leicht lenkend	+	+	+																			
verschleißarm	+	+	+																			
stoßfest	+	+	+																			
bodenschonend	+	+	+																			
witterungsbeständig	+	+	+																			
<p>Vulkollan® Reifen ballig gegossen Felge - Vollkern aus Aluminium</p>																						

### Technische Details

<b>ORDERNO (Artikel-nummer)</b>	69B/100-40 BA
<b>WDAB (Rad-Ø A x Breite B / mm)</b>	100x40
<b>LC (Tragkraft / kg)</b>	280
<b>H (Bauhöhe H / mm)</b>	125
<b>TP (Plattengröße / mm)</b>	135x105
<b>HS (Lochabstand / mm)</b>	105x80
<b>HD (Loch-Ø / mm)</b>	11
<b>WB (Radlager)</b>	Kugellager