

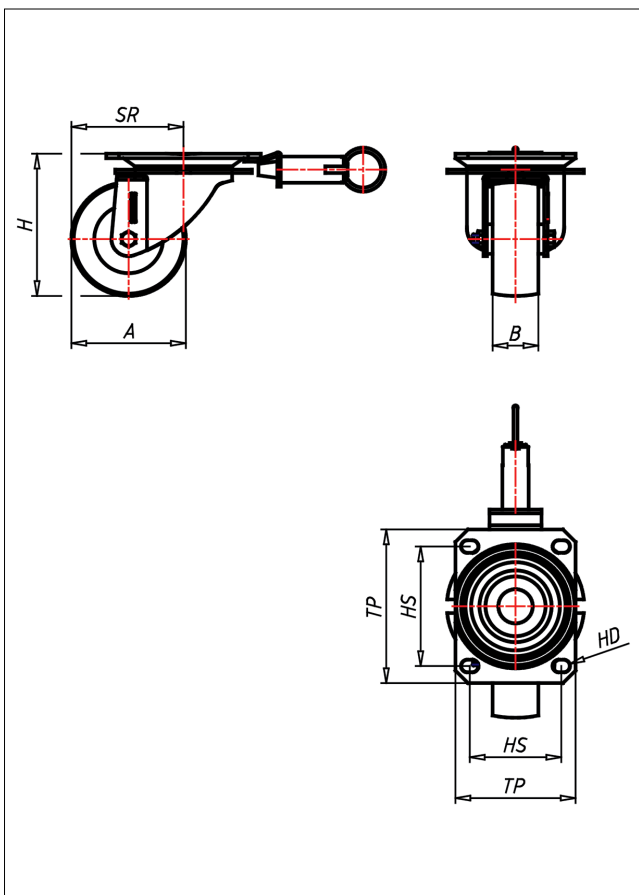

69F/69R-BA

Lenkrolle mit Totalfeststeller



69-BA



LENKRÖLLE	LENKRÖLLE MIT TOTALFESTSTELLER	90° RICHTUNGSFESTSTELLER																				
 <ul style="list-style-type: none"> • minimaler Rollwiderstand • geräuscharmer Lauf • sehr niedrige Abriebswerte • lange Lebensdauer • sehr beständig gegen viele aggressive Medien <p>Vulkollan® Reifen ballig gegossen Felge - Vollkern aus Aluminium</p> 	 <p>sehr großes Schwenklager, Staubschutzring, starker Zentralbolzen verschraubt - gesichert</p>	 <p>AUSWAHLHILFE:</p> <table border="1"> <tr> <td>leicht lenkend</td> <td>+</td> <td>+</td> <td>++</td> </tr> <tr> <td>verschleißarm</td> <td>+</td> <td>+</td> <td>+</td> </tr> <tr> <td>stoßfest</td> <td>+</td> <td>+</td> <td>+</td> </tr> <tr> <td>bodenschonend</td> <td>+</td> <td>+</td> <td>+</td> </tr> <tr> <td>witterungsbeständig</td> <td>+</td> <td>+</td> <td>+</td> </tr> </table>	leicht lenkend	+	+	++	verschleißarm	+	+	+	stoßfest	+	+	+	bodenschonend	+	+	+	witterungsbeständig	+	+	+
leicht lenkend	+	+	++																			
verschleißarm	+	+	+																			
stoßfest	+	+	+																			
bodenschonend	+	+	+																			
witterungsbeständig	+	+	+																			

Technische Details

ORDERNO (Artikel-nummer)	69R/150-50 BA
WDAB (Rad-Ø A x Breite B / mm)	150x50
LC (Tragkraft / kg)	700
H (Bauhöhe H / mm)	204
TP (Plattengröße / mm)	135x105
HS (Lochabstand / mm)	105x80
HD (Loch-Ø / mm)	11
SR (Schwenkradius / mm)	123
WB (Radlager)	Kugellager