

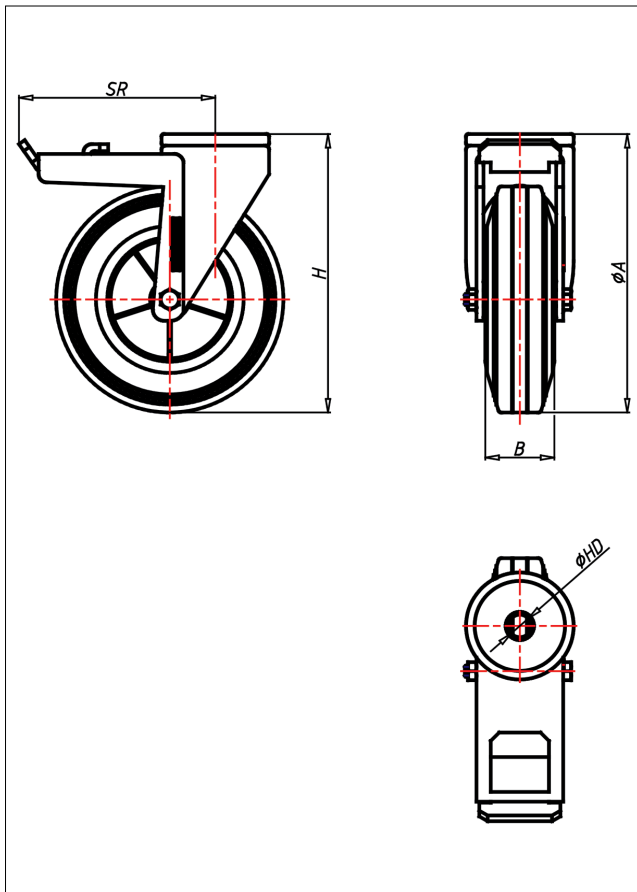

# CRT-DGB/DG

## Lenkrolle mit Totalfeststeller



### CR-DG



LENKROLLE	LENKROLLE MIT TOTALFESTSTELLER																
<ul style="list-style-type: none"> <li>• spurfrei - bodenschonend</li> <li>• hoher Fahrkomfort</li> <li>• sehr lauffähig</li> <li>• geringer Rollwiderstand</li> <li>• abriebfest</li> </ul> <p>ELASTIK-Vollgummi Felge Kunststoff → Seite 262</p>	<ul style="list-style-type: none"> <li>• zweifaches Kugellager - vernietet</li> <li>• Stahlkugeln gehärtet</li> <li>• Radachse verschraubt, verzinkt</li> </ul> <p>→ Seite 62</p>	<p>AUSWAHLHILFE:</p> <table border="1"> <tr> <td>leicht lenkend</td> <td>X</td> <td>X</td> </tr> <tr> <td>verschleißarm</td> <td>X</td> <td>X</td> </tr> <tr> <td>stoßfest</td> <td>X</td> <td>X</td> </tr> <tr> <td>bodenschonend</td> <td>X</td> <td>X</td> </tr> <tr> <td>witterungsbeständig</td> <td>X</td> <td>X</td> </tr> </table>	leicht lenkend	X	X	verschleißarm	X	X	stoßfest	X	X	bodenschonend	X	X	witterungsbeständig	X	X
leicht lenkend	X	X															
verschleißarm	X	X															
stoßfest	X	X															
bodenschonend	X	X															
witterungsbeständig	X	X															

### Technische Details

<b>ORDERNO (Artikel-nummer)</b>	CRT 125 DG
<b>WDAB (Rad-Ø A x Breite B / mm)</b>	125x38
<b>LC (Tragkraft / kg)</b>	110
<b>H (Bauhöhe H / mm)</b>	154
<b>HD (Loch-Ø / mm)</b>	12.5
<b>SR (Schwenkradius / mm)</b>	108
<b>WB (Radlager)</b>	Nylon-Gleitlager