

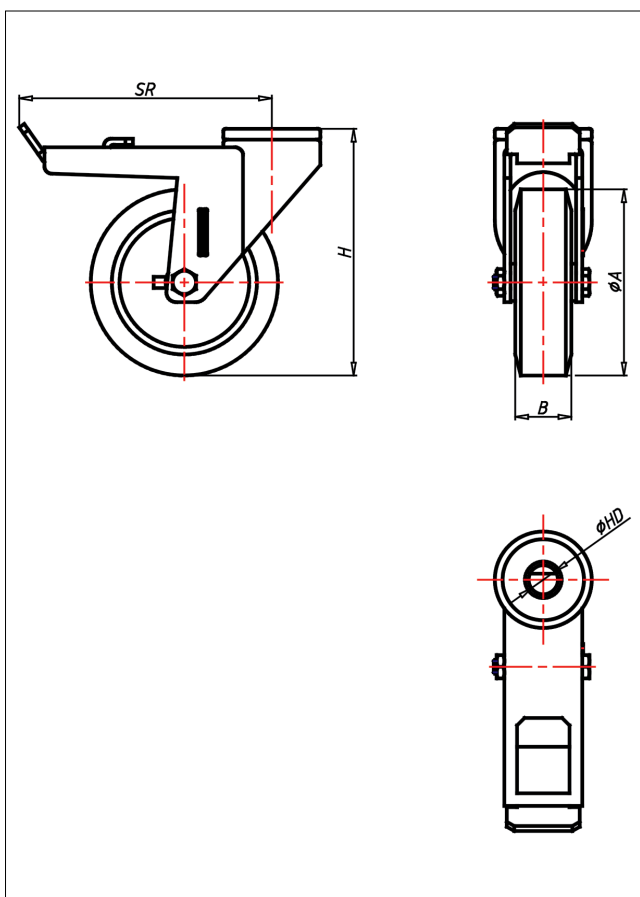

CRT/CRST-A/AK/AB

Lenkrolle mit Totalfeststeller



CR-A



SWIVEL CASTOR	SWIVEL CASTOR WITH TOTAL LOCK	
<ul style="list-style-type: none"> • silent in motion • low rolling resistance • high abrasion and tear resistance • high resistance to shocks • easy to clean • good chemical resistance 	<p>Medium duty bolt hole castor, finish: electro-zinc plated, swivel fork with single bolt hole, double ball bearing - revited, hardened steel balls, wheel axle bolted, total lock</p> <p>→ page 62</p>	<p>SELECTION CRITERIA:</p> <ul style="list-style-type: none"> swivels easily wear resistant shock proof floor protective weather proof

Technische Details

ORDERNO (Artikel-nummer)	CRT 175 AK
WDAB (Rad-Ø A x Breite B / mm)	175x40
LC (Tragkraft / kg)	300
H (Bauhöhe H / mm)	216
HD (Loch-Ø / mm)	12.5
SR (Schwenkradius / mm)	168
WB (Radlager)	Kugellager