

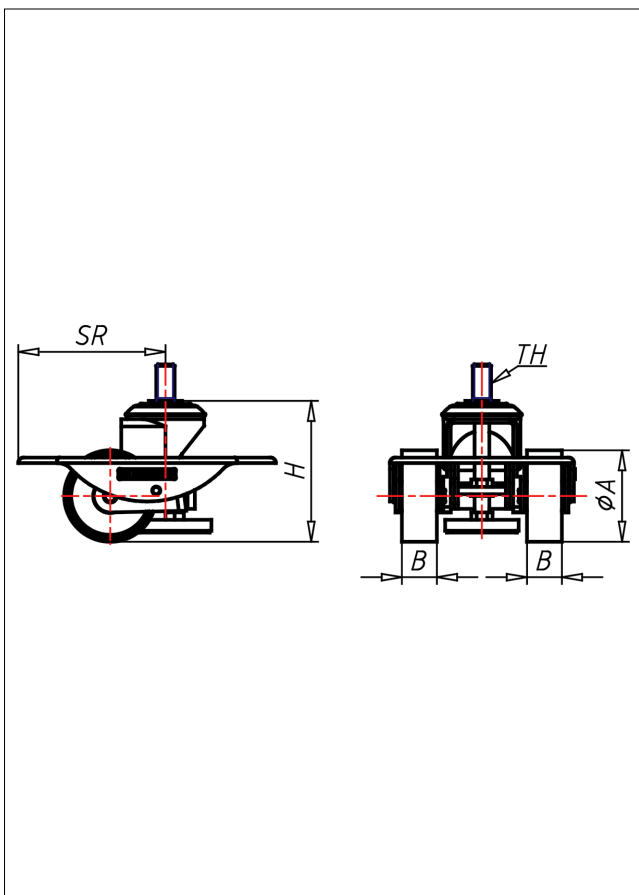

HRX-P/G

Heberolle



HRX Heberolle



DIE HEBEROLLE MIT INTEGRIERTEM, NIVELLIERBAREM MASCHINENFUSS SORGT FÜR OPTIMALE STANDFESTIGKEIT.

Einfache Bedienung durch Fußpedale. In jeder Stellung bedienbar - 360° drehbar. Rampen können bis 20° Steigung befahren werden.

<p>Rad P Polyamid 6 - 1. Wahl</p> <p>→ Seite 272</p> 	<p>Rad G Thermoplastisches Elastomer Felge Polyamid 6</p> <p>→ Seite 268</p> 	<p>Gehäuse aus Edelstahl 1.4301 Drehkopf mit zweifachem Kugelkranz Pedal: Länge 140 mm, Breite 100 mm Nivellierbarer Standfuß mit Antirutschsohle aus NBR-Gummi, Ø 40 mm</p> <ul style="list-style-type: none"> niedrige Bauhöhe sehr gute Manövrierbarkeit
-----------------------------------------------------------------------------------------------------------------------------------------------	----------------------------------------------------------------------------------------------------------------------------------------------------------------------------	-------------------------------------------------------------------------------------------------------------------------------------------------------------------------------------------------------------------------------------------------------------------------------------------------

Technische Details

ORDERNO (Artikel-nummer)	HRX M10 50 P
WDAB (Rad-Ø A x Breite B / mm)	50x19+19
LC (Tragkraft / kg)	100
H (Bauhöhe H / mm)	77
TH (Gewinde)	M10x20
SR (Schwenkradius / mm)	80
WB (Radlager)	Gleitlager