

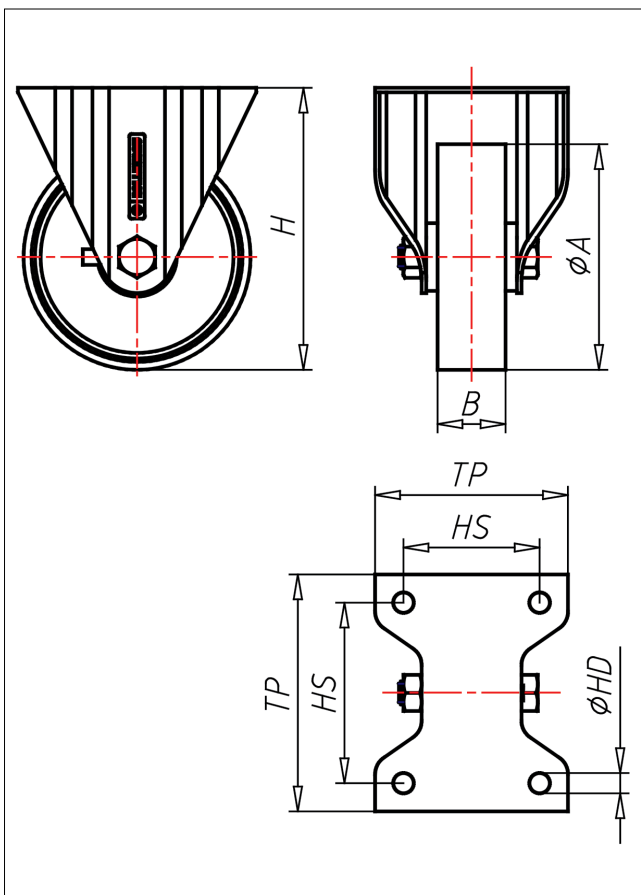

INF/INVF-PBX/P/PL

Bockrolle

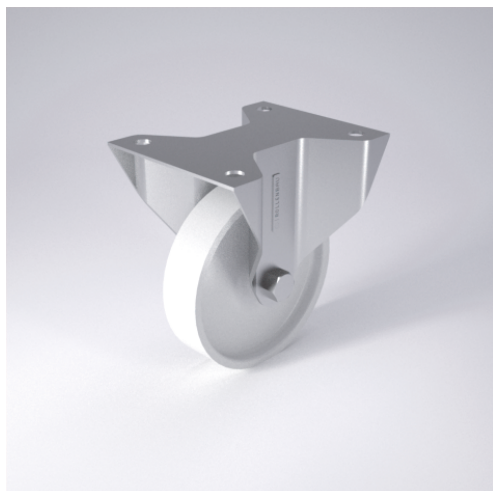

IN-P



LENKROLLE	LENKROLLE MIT TOTALFESTSTELLER	BOCKROLLE															
<ul style="list-style-type: none"> • leichter Lauf auf glatten Böden • stoß- und schlagfest • hohe Abriebfestigkeit • leicht zu reinigen • sehr beständig gegen viele aggressive Medien Polyamid 6 - 1. Wahl → Seite 272	 zweifaches Kugellager - verschraubt, Staubschutzring, Radachse verschraubt - gesichert, Edelstahl poliert → Seite 110	AUSWAHLHILFE: <table border="1"> <tr> <td>leicht lenkend</td> <td>+</td> <td>++</td> </tr> <tr> <td>verschleißarm</td> <td>x</td> <td>x</td> </tr> <tr> <td>stoßfest</td> <td>x</td> <td>x</td> </tr> <tr> <td>bodenschonend</td> <td>x</td> <td>x</td> </tr> <tr> <td>witterungsbeständig</td> <td>x</td> <td>x</td> </tr> </table>	leicht lenkend	+	++	verschleißarm	x	x	stoßfest	x	x	bodenschonend	x	x	witterungsbeständig	x	x
leicht lenkend	+	++															
verschleißarm	x	x															
stoßfest	x	x															
bodenschonend	x	x															
witterungsbeständig	x	x															

Technische Details

ORDERNO (Artikel-nummer)	INF 80 P
WDAB (Rad-Ø A x Breite B / mm)	80x30
LC (Tragkraft / kg)	120
H (Bauhöhe H / mm)	100
TP (Plattengröße / mm)	105x85
HS (Lochabstand / mm)	80x60
HD (Loch-Ø / mm)	9
WB (Radlager)	Polyamid-Gleitlager